

HYPHERPRO

STEERING DAMPER MOUNTING KIT

for

KTM 1290 Super Duke R '14-'16 & 2017> / GT 2016>

MK-KT12-B002 A PART LIST

SD stroke 68 REVERSED	1	-	-
Damper Clamp [MP-DB0003]	1	-	-
O-Ring	1	-	-
Frame Bracket [MP-FRMK35]	1	-	-
M6x20 Low head	1	-	-
Washer M6 ϕ 12	1	-	-
-	-	-	-
-	-	-	-

ALL IDEAS, DESIGNS ARRANGEMENTS AND PLANS INDICATED OR REPRESENTED BY THIS DRAWING ARE OWNED BY HYPERPRO AND WERE CREATED, EVOLVED AND DEVELOPED FOR USE ON AND IN CONNECTION WITH THE SPECIFIC PROJECT. NONE SUCH IDEAS, DESIGNS, ARRANGEMENTS OR PLANS SHALL BE USED BY OR DISCLOSED TO ANY PERSON, FIRM OR CORPORATION FOR ANY PURPOSE WHATSOEVER WITHOUT THE WRITTEN PERMISSION OF HYPERPRO.

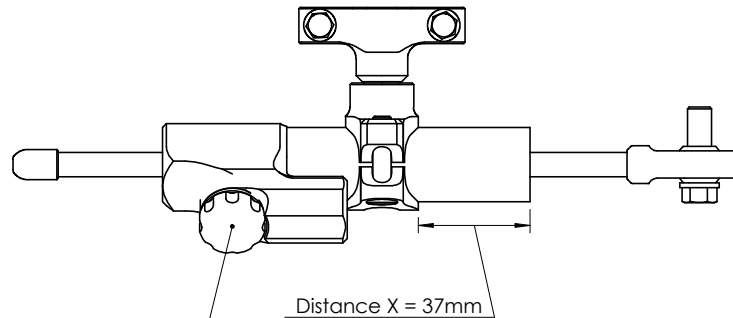

Damping adjustment knob:
- turn CW to increase damping
- turn CCW to decrease damping

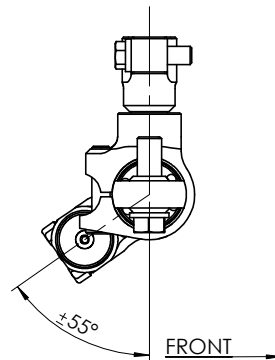

REPLACES THE ORIGINAL STEERING DAMPER

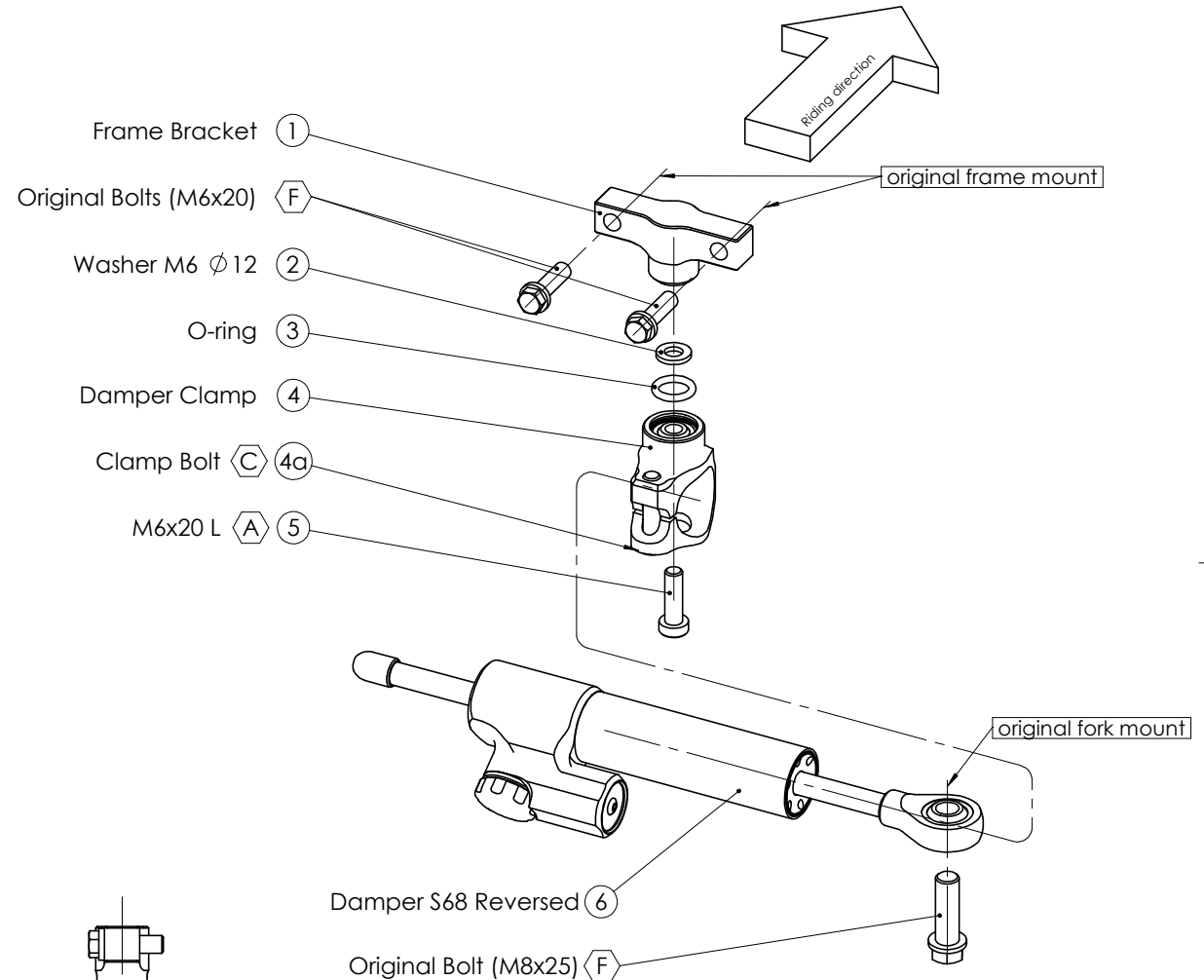

* TORQUES use Loctite 243 or similar
A: 5-9Nm / 44-80Lbs.In / 4.0-6.4Lbs.Ft
B: 14-17Nm / 124-150Lbs.In / 10.3-12.5Lbs.Ft
C: 6Nm / 53Lbs.In / 4.4Lbs.Ft

D: 8Nm / 70Lbs.In / 5.9Lbs.Ft
E: 55Nm / 486Lbs.In / 40Lbs.Ft
F: Factory torque (see owners manual)

HYPERPRO

STEERING DAMPER MOUNTING KIT

for

KTM 1290 Super Duke R '14-'16 & 2017> / GT 2016>

MK-KT12-B002 A INSTALLATION INSTRUCTIONS

In general:

HYPERPRO can not be held responsible in any way for any form of physical, material, financial or other damage arising from use, assembly or overhaul of HYPERPRO products. HYPERPRO reserves the right to make changes without prior notice.

This product is ONLY TO BE INSTALLED BY A PROFESSIONAL MECHANIC.

This product is only to be used for the motorcycle brand, model and year stated specifically on top of the pages of this manual.

DO NOT attempt to install this product on motorcycles from any different brand, model and/or year than stated on the pages of this manual.

DO NOT use this kit for cars, boats, jet skis, snowmobiles, ATV's, aircraft, hovercrafts or any other vehicle and/or purpose.

HYPERPRO steering dampers are FOR RACE USE ONLY, NOT FOR HIGHWAY USE!

Before installation:

- Please read the entire manual carefully before starting the installation!
- Check if you have all the tools required. Good tools are a must.
- Protect your bike at the most important places in and around the work area (e.g. tank, fairing, frame, etc.), with a blanket, towel or similar.

During installation:

- Check all operations and parts carefully before, during and after performing each step.
- Clean all surfaces that are required for fitting parts together or for applying self adhesives or loctite, thoroughly with contactcleaner or another degreaser, unless otherwise stated.
- Be careful not to damage or scratch any part of your bike.
- ALWAYS work relaxed and concentrated!! It is very easy to damage something or make a mistake.

After installation:

- Check and make sure that there is no contact between any part of the steering damper kit and any part of the motorcycle. The kit should not hit anything. Steering movement should not be limited by the steering damper. If the steering movement is limited, adjust the position of the tube in the clamp until steering movement is normal again. Do not forget to tighten the clamp bolt again!
- ALWAYS check the steering movement and feeling before each ride !
- FIRST RIDES: Start with the damper turned fully open (turn adjuster knob fully counter clockwise). Start adjusting in between rides with steps of MAX. 2 CLICKS (0.25 TURN) EACH TIME, until the damper is working satisfactory for your riding style.
- NEVER USE MAXIMUM SETTING, ALWAYS OPEN AT LEAST 2 CLICKS (0.25 TURN).
- WARNING ! DAMPER HAS AN ACTIVE / SPEEDSENSITIVE DAMPING SYSTEM;
 - Steering with NORMAL MOVEMENT should be FREE !!
 - Steering with FAST MOVEMENT should be CONTROLLED BY DAMPER !!
- HYPERPRO uses a special seal to reduce friction. The seal uses an oil film to work properly. It is normal that some oil can appear on the pistonrod.
- Damper works with oil: DAMPING CAN BE HARDER AT LOWER TEMPERATURES!

Step 1: remove the original steering damper

Remove the 3 mounting bolts and remove the complete steering damper assembly. Keep the bolts, they are needed to install the replacement damper.

Step 2: install the frame bracket

Assemble the frame bracket using:

- Frame bracket (1)
- Washer M6 \varnothing 12 (2)
- 1x O-Ring (3)
- Damper Clamp (4)
- Bolt M6x20 Low head (5)

Mount the washer (2), the O-ring (3) and the damper clamp (4) to the frame bracket (1), using the M6 bolt (5). Tighten the bolt with a torque of approx.5-9Nm/44-80Lbs.In/4.0-6.4Lbs.Ft.

Install the bracket assembly to the motorcycle using the original M6 bolts and tighten them to the factory torque settings (see owners manual) or approx.5-9Nm/44-80Lbs.In/4.0-6.4Lbs.Ft.

Step 3: install the steering damper

Install the steering damper using:

- Steering damper, stroke 68 REVERSED (6)

Ensure that the clamp bolt (4a) of the damper clamp is pointing to the radiator. Shove the damper (6), with the ball-joint first, through the clamp (4) until the distance "X" reached. Rotate the damper body to the correct angle and tighten the clamp bolt (4a) with a torque of approx. 6Nm/53Lbs.In/4.4Lbs.Ft.

Mount the ball-joint to the fork using the original M8x25 bolt and tighten to the factory torque settings (see owners manual) or approx.14-17Nm/124-150Lbs.In/10.3-12.5Lbs.Ft.

Check if the damper is properly aligned. Check if the damper does not touch anything (e.g. radiator, bodywork) when steering from left to right. Check if the bike can make it's full steering angle from left to right.

If necessary to improve, it is possible to:

- adjust the steering limiters on the lower triple clamp.
 - reposition the damper body in the clamp by loosening the clamp bolt (4a).
- Do not forget to re-tighten the bolts.