

FTRYA001R



CAMBIO ROVESCiato

CAMBIO NORMALE

!
 IT) E' necessario l'intervento di personale professionale per tutti i prodotti che necessitano di installazione.
 EN) The assistance of professional staff is necessary for all parts which require installation.
 ES) Se necesita que sea montado por profesionales para todos los productos que necesitan instalación.
 FR) L'assistance d'un professionnel est nécessaire pour toutes les pièces qui nécessitent une installation.
 DEU) Der Eingriff von Fachpersonal ist notwendig für alle Artikel die installiert/montiert werden müssen.

SFILARE LA VITE ORIGINALE DI FISSAGGIO MOTORE/TELAIO DAL LATO SX E RE-INSERIRLA DA LATO DX
 REMOVE THE ORIGINAL FRAME/ENGINE SCREW FROM LEFT SIDE AND RE-INSERT IT FROM RIGHT SIDE

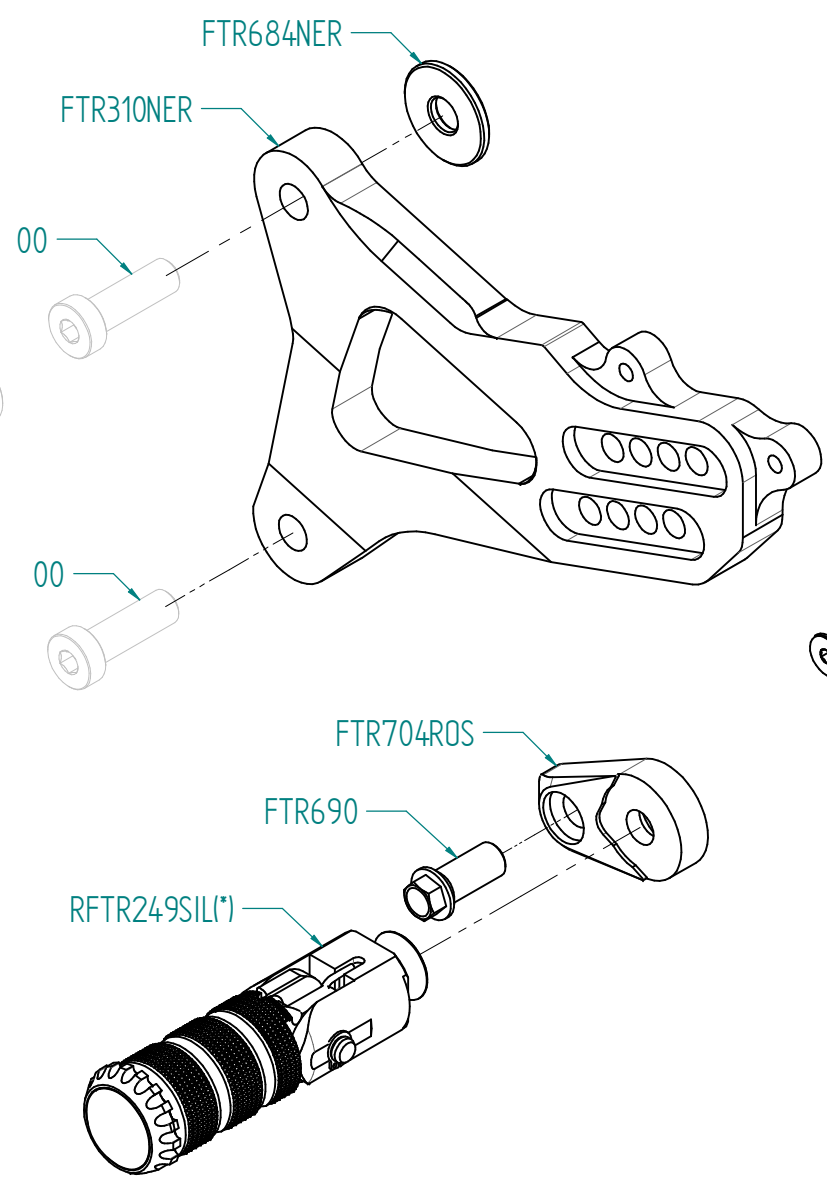
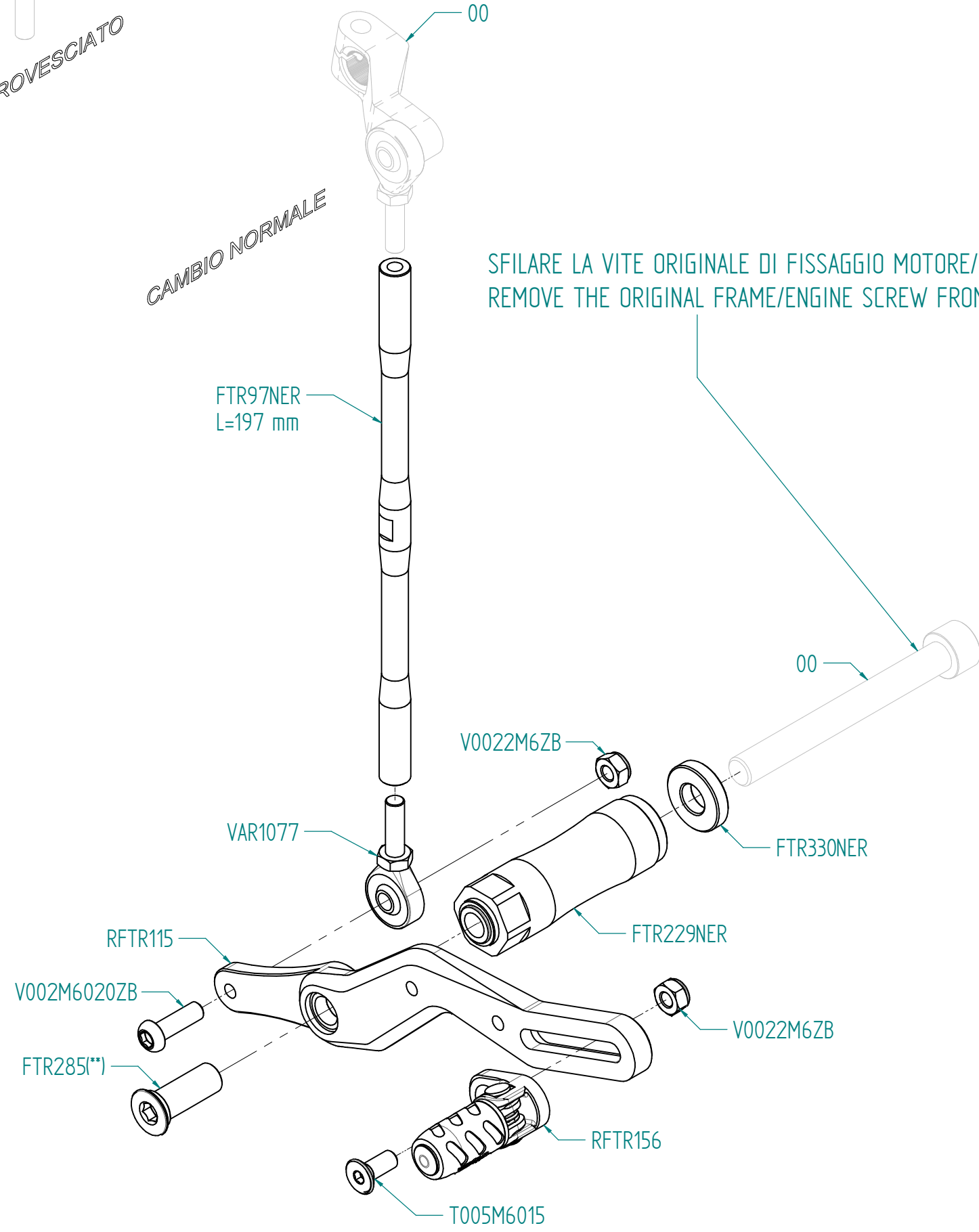
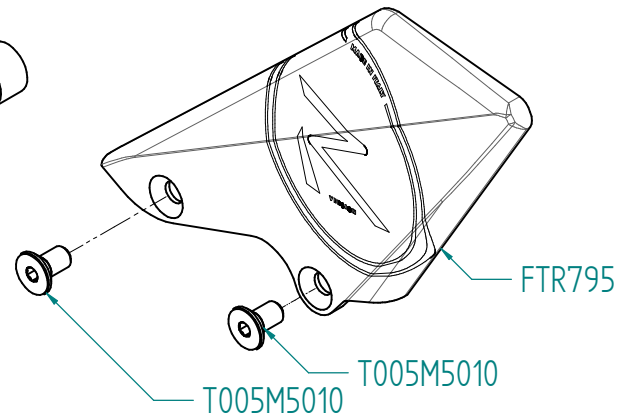
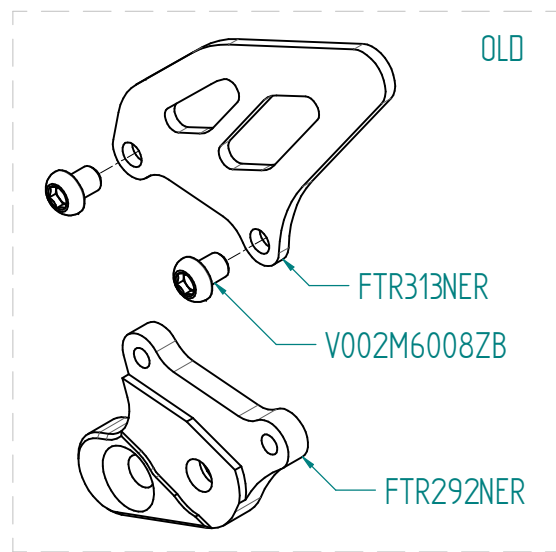

ITALIA	(00) PARTE ORIGINALE
	(*) BLOCCARE CON FRENAFILETTI DEBOLE
	(**) BLOCCARE CON FRENAFILETTI MEDIO
	CAMBIO NORMALE
	CAMBIO ROVESCiato
VERIFICARE SERRAGGIO VITI PRIMA DELL'UTILIZZO	
PRIMA DI ORDINARE VERIFICARE L'ULTIMA RELEASE SUL SITO	

ENGLAND	(00) OEM PART
	(*) LOCKING WITH LOW STRENGTH THREAD LOCKER
	(**) LOCKING WITH MEDIUM STRENGTH THREAD LOCKER
	NORMAL MODE
	REVERSE MODE
CONTROL THE THIGHTENING'S SCREW BEFORE USING	
BEFORE ORDER CHECKING THE LATEST RELEASE ON WEBSITE	

FRANCE	(00) PIECE ORIGINE
	(*) BLOCAGE AVEC FREIN FILET FAIBLE
	(**) BLOCAGE AVEC FREIN FILET MOYENNE
	MONTAGE VITESSE NORMALE
	MONTAGE VITESSE INVERSEE
VERIFIER SERRAGE AVANT UTILISATION	
AVANT DE ORDONNER ON DOIT VÉRIFIER LA DERNIÈRE RELEASE SUR LE SITE INTERNET	

DEUTSCHLAND	(00) ORIGINAL TEIL
	(*) BEFESTIGEN MIT SWACH SCHRAUBEN SICHERUNGSMITTEL
	(**) BEFESTIGEN MIT MITTLEREN SCHRAUBEN SICHERUNGSMITTEL
	EINBAU MIT NORMALE SCHALTUNG
	EINBAU MIT GEKIPPTER SCHALTBEHEL
VOR DEN GEBRAUCH SCHRAUBEN PRÜFEN	
VOR DER BESTELLUNG ÜBERPRÜFEN SIE BITTE DIE LETZTE VERSION DIESER ARTIKEL AUF DER INTERNET SEITE VON LIGHTTECH	

ESPAÑA	(00) PIEZA ORIGINAL
	(*) SELLAR CON SELLADOR DEBIL
	(**) SELLAR CON SELLADOR MEDIO
	MONTAJE CAMBIO NORMAL
	MONTAJE CAMBIO INVERSO
VERIFICAR EL APRIETE ANTES DE UTILIZARLO	
ANTES DE HACER EL PEDIDO, VERIFICAR LA ÚLTIMA VERSION EN LA WEB LIGHTTECH	

FTRYA001R

Questo kit non utilizza la molla di richiamo
leva freno e l'interruttore luce stop originali.
Kit stop idraulico opzionale RFTR93

This kit doesn't use the original spring lever
return and the brake switch.
Optional hydraulic stop switch kit RFTR93

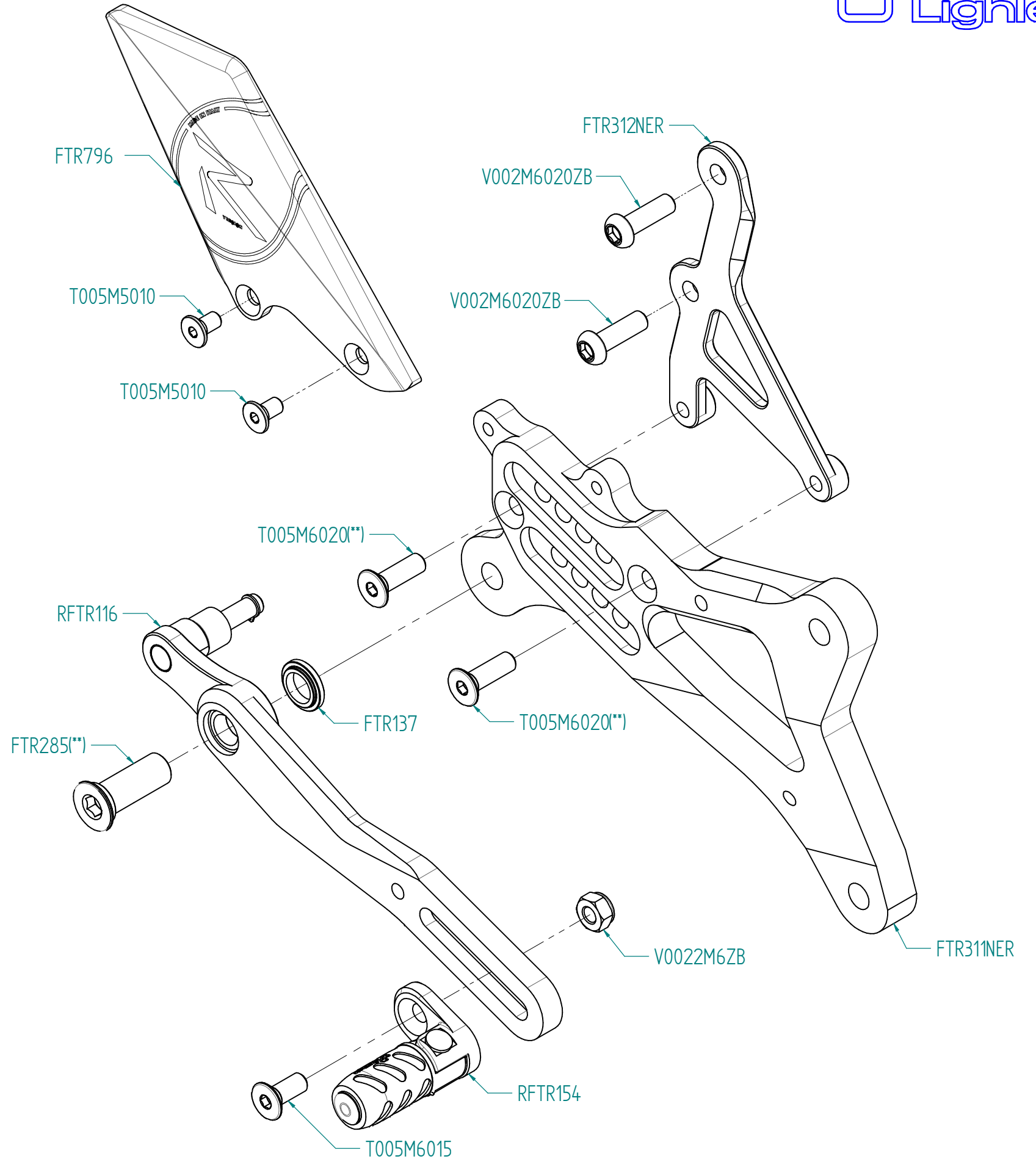
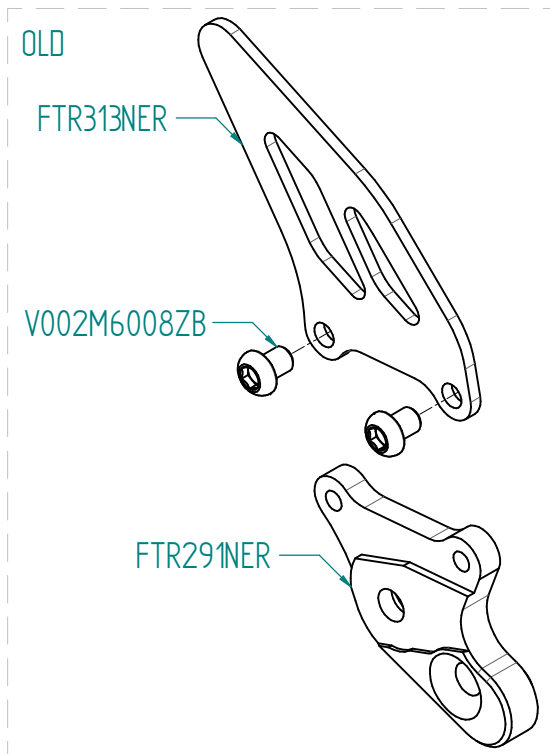
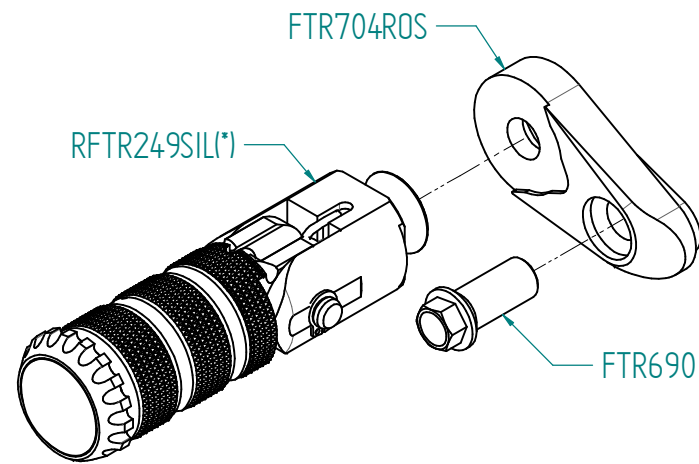

ITALIA	(00) PARTE ORIGINALE
	(*) BLOCCARE CON FRENAFILETTI DEBOLE
	(**) BLOCCARE CON FRENAFILETTI MEDIO
	CAMBIO NORMALE
	CAMBIO ROVESCIAIO
VERIFICARE SERRAGGIO VITI PRIMA DELL'UTILIZZO	
PRIMA DI ORDINARE VERIFICARE L'ULTIMA RELEASE SUL SITO	

ENGLAND	(00) OEM PART
	(*) LOCKING WITH LOW STRENGHT THREAD LOCKER
	(**) LOCKING WITH MEDIUM STRENGHT THREAD LOCKER
	NORMAL MODE
	REVERSE MODE
CONTROL THE THIGHTENING'S SCREW BEFORE USING	
BEFORE ORDER CHECKING THE LATEST RELEASE ON WEBSITE	

FRANCE	(00) PIECE ORIGINE
	(*) BLOCAGE AVEC FREIN FILET FAIBLE
	(**) BLOCAGE AVEC FREIN FILET MOYENNE
	MONTAGE VITESSE NORMALE
	MONTAGE VITESSE INVERSEE
VERIFIER SERRAGE AVANT UTILISATION	
AVANT DE ORDONNER ON DOIT VÉRIFIER LA DERNIÈRE RELEASE SUR LE SITE INTERNET	

DEUTSCHLAND	(00) ORIGINAL TEIL
	(*) BEFESTIGEN MIT SWACH SCHRAUBEN SICHERUNGSMITTEL
	(**) BEFESTIGEN MIT MITTLEREN SCHRAUBEN SICHERUNGSMITTEL
	EINBAU MIT NORMALE SCHALTUNG
	EINBAU MIT GEKIPPTER SCHALTHEBEL
VOR DEN GEBRAUCH SCHRAUBEN PRÜFEN	
VOR DER BESTELLUNG ÜBERPRÜFEN SIE BITTE DIE LETZTE VERSION DIESER ARTIKEL AUF DER INTERNET SEITE VON LIGHTTECH	

ESPAÑA	(00) PIEZA ORIGINAL
	(*) SELLAR CON SELLADOR DEBIL
	(**) SELLAR CON SELLADOR MEDIO
	MONTAJE CAMBIO NORMAL
	MONTAJE CAMBIO INVERSO
VERIFICAR EL APRIETE ANTES DE UTILIZARLO	
ANTES DE HACER EL PEDIDO, VERIFICAR LA ULTIMA VERSION EN LA WEB LIGHTTECH	