

HYPHERPRO

STEERING DAMPER MOUNTING KIT for APRILIA RSV1000 MILLE Model 1998 - 2000<

MK-AP10-0001 PART LIST			
SD stroke 75	1	-	-
Fork clamp Ø51	1	-	-
Spacer Type 1	1	-	-
Tube Adapter RSV	1	-	-
O-Ring	1	-	-
M8x35 Button head	1	-	-
Steering Lock Limiters	2	-	-
-	-	-	-

ALL IDEAS, DESIGNS ARRANGEMENTS AND PLANS INDICATED OR REPRESENTED BY THIS DRAWING ARE OWNED BY HYPERPRO AND WERE CREATED, EVOLVED AND DEVELOPED FOR USE ON AND IN CONNECTION WITH THE SPECIFIC PROJECT. NONE SUCH IDEAS, DESIGNS, ARRANGEMENTS OR PLANS SHALL BE USED BY OR DISCLOSED TO ANY PERSON, FIRM OR CORPORATION FOR ANY PURPOSE WHATSOEVER WITHOUT THE WRITTEN PERMISSION OF HYPERPRO.

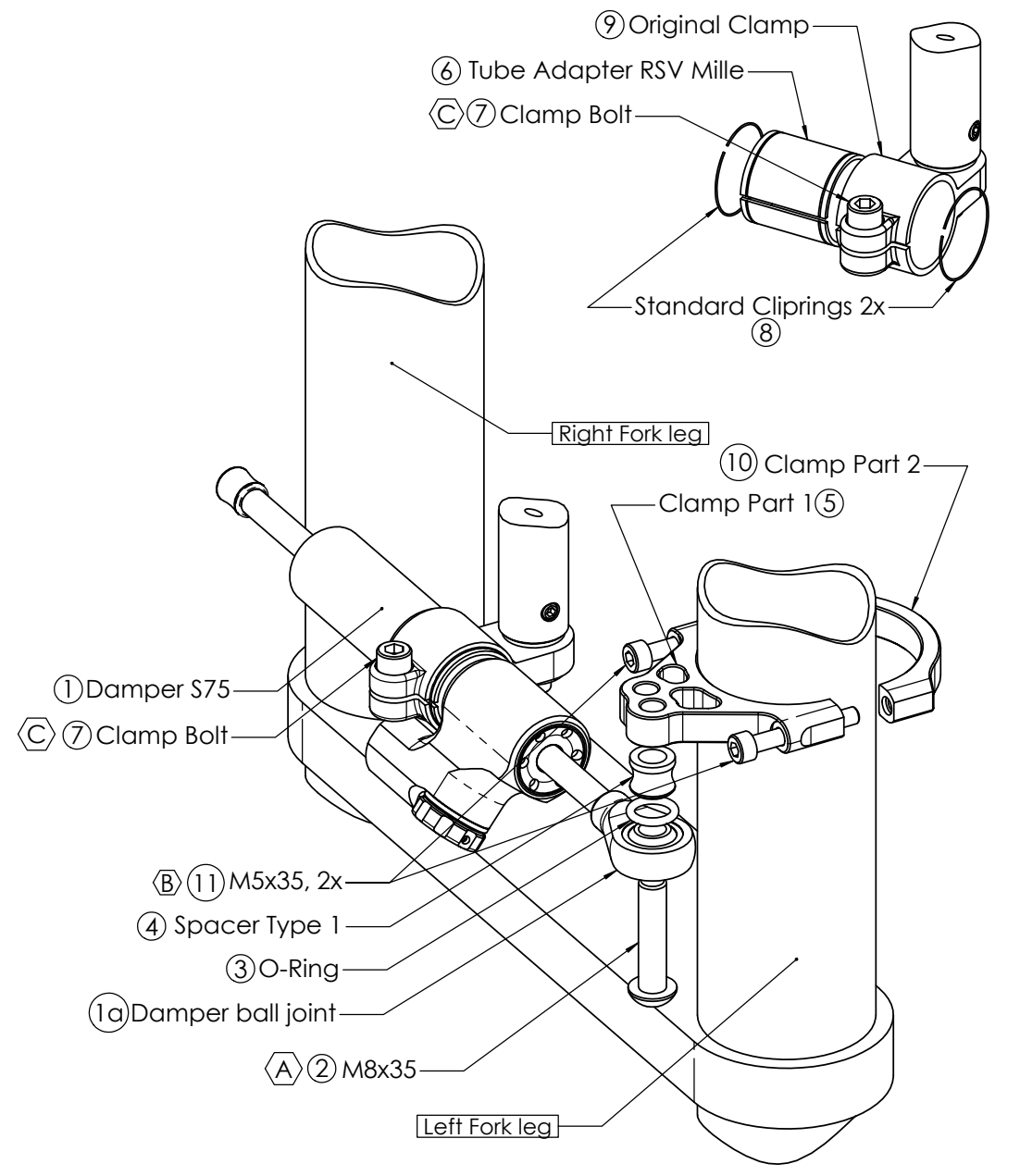
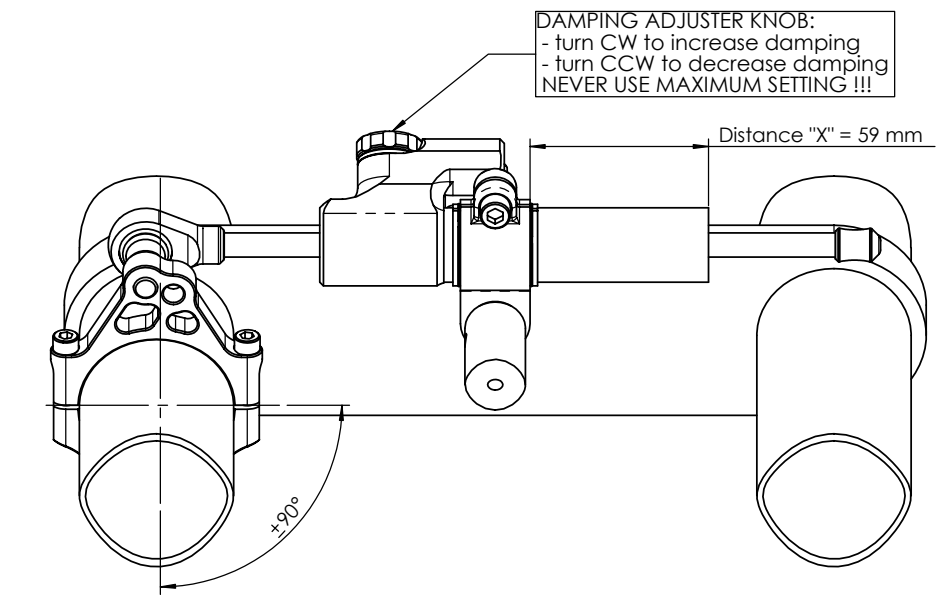

1
of 2

Ⓟ A	14-17Nm / 124-150Lbs.In / 10.3-12.5Lbs.Ft
Ⓟ B	8Nm / 70Lbs.In / 5.9Lbs.Ft
Ⓢ C	6Nm / 53Lbs.In / 4.4Lbs.Ft

See WWW.HYPERPRO.COM for the latest pictures, modifications, specs. and e-drawings of this steering damper kit.

HYPERPRO

STEERING DAMPER MOUNTING KIT

for

APRILIA RSV1000 MILLE Model 1998 - 2000<

MK-AP10-O001 INSTALLATION INSTRUCTIONS

In general:

HYPERPRO can not be held responsible in any way for any form of physical, material, financial or other damage arising from use, assembly or overhaul of HYPERPRO products. HYPERPRO reserves the right to make changes without prior notice.

This product is ONLY TO BE INSTALLED BY A PROFESSIONAL MECHANIC.

This product is only to be used for the motorcycle brand, model and year stated specifically on top of the pages of this manual.

DO NOT attempt to install this product on motorcycles from any different brand, model and/or year than stated on the pages of this manual.

DO NOT use this kit for cars, boats, jet-skies, snowmobiles, ATV's, aircraft, hovercrafts or any other vehicle and/or purpose.

HYPERPRO steering dampers are FOR RACE USE ONLY, NOT FOR HIGHWAY USE!

Before installation:

- Please read the entire manual carefully before starting the installation!
- Check if you have all the tools required. Good tools are a must.
- Protect your bike at the most important places in and around the work area (e.g. tank, fairing, frame, etc.), with a blanket, towel or similar.

During installation:

- Check all operations and parts carefully before, during and after performing each step.
- Clean all surfaces that are required for fitting parts together or for applying self adhesives or loctite, thoroughly with contact cleaner or another degreaser, unless otherwise stated.
- Be careful not to damage or scratch any part of your bike.
- ALWAYS work relaxed and concentrated!! It is very easy to damage something or make a mistake.

After installation:

- Check and make sure that there is no contact between any part of the steering damper kit and any part of the motorcycle. The kit should not hit anything. Steering movement should not be limited by the steering damper. If the steering movement is limited, adjust the position of the tube in the clamp until steering movement is normal again. Do not forget to tighten the clamp bolt again!
- ALWAYS check the steering movement and feeling before each ride!
- FIRST RIDES: Start with the damper turned fully open (turn adjuster knob fully counter clockwise). Start adjusting in between rides with steps of MAX. 2 CLICKS (0.25 TURN) EACH TIME, until the damper is working satisfactory for your riding style.
- NEVER USE MAXIMUM SETTING, ALWAYS OPEN AT LEAST 2 CLICKS (0.25 TURN).

- WARNING! DAMPER HAS AN ACTIVE / SPEEDSENSITIVE DAMPING SYSTEM;
 - Steering with NORMAL MOVEMENT should be FREE !!
 - Steering with FAST MOVEMENT should be CONTROLLED BY DAMPER !!
- HYPERPRO uses a special seal to reduce friction. The seal uses an oil film to work properly. It is normal that some oil can appear on the pistonrod.
- Damper works with oil: DAMPING CAN BE HARDER AT LOWER TEMPERATURES!

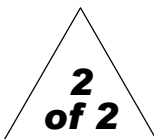

See WWW.HYPERPRO.COM for the latest pictures, modifications, specs. and e-drawings of this steering damper kit.

Step 1: Remove original steering damper

Step 2: Damper & clamp pre-assembly

Pre-assemble the clamps onto the damper using:

- Steering damper (1)
- Bolt M8x35 Button head (2)
- 1x O-Ring (3)
- Spacer Type 1 (4)
- Fork clamp Part 1 (5)

Disassemble the fork clamp. Fit clamp part 1 (5) to the balljoint of the steering damper (1a) using the M8x35 bolt (2), O-Ring (3) and spacer type 1 (4). Make sure it is assembled according to the pictures on page 1. Next tighten the bolt with a torque of approx. 14-17Nm/124-150Lbs.In/10.3-12.5Lbs.Ft.

Step 3: installing the steering lock limiters

Install the lock limiters using:

- Rubber 2mm steering lock limiters (self-adhesive)

Clean and degrease the left and right steering lock surfaces on the bottom of the steering head (see illustration). Stick the bumprubbers on the cleaned surfaces, so that the max steering angle will be limited by a few millimeters.

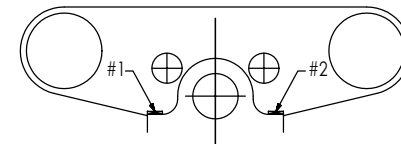

Step 4: replacing the original damper

- Damper pre-assembly (from Step 2)
- Tube adapter for RSV Mille (6)

Remove the black plastic cover from the bottom of the lower triple tree, providing access to the bottom of the cockpitframe. Loosen and remove the brake hose clamp from the front of the lower triple tree for better access.

Loosen clamp bolt (7), remove the standard cliprings (8) (do not throw away!) and remove the M6 at the original damper ball joint. Mount tube adapter (6) in standard clamp (9) with opening in the same position and reposition the standard cliprings (8). Do not tighten the clamp bolt (7) of the damper clamp (9) yet to install the damper to the front fairing subframe. Make sure it is assembled according to the pictures on page 1. Position the clamp at distance "X" (=59mm) and the damper body at the correct angle and tighten the clamp bolt with a torque of approximately 6Nm/53Lbs.In/4.4Lbs.Ft.

Step 5: installing the fork clamp

- Fork clamp Part 2 (10)
- 2x Bolt M5x35 (11)

Place the 2nd part of the fork clamp (10) on the fork leg, opposite to the 1st part (5). Fit the M5 bolts (11) and tighten them lightly and evenly. Check if the damper is level horizontally and tighten the bolts with a torque of approx. 8Nm/70Lbs.In/5.9Lbs.Ft.

Make sure that the damper has at least 2 mm clearance at full steering lock.

Check if the damper does not touch anything when steering from left to right. Check if the bike can make it's full steering angle from left to right, without being obstructed by the damper. If necessary re-position the clamp and re-tighten the bolts.