

# HYPHERPRO

## STEERING DAMPER MOUNTING KIT

for

**BMW R1100R**  
Model 1993 ->

### MK-BM11-0001 PART LIST

SD stroke 75	1	-	-
Tube Clamp TYPE 1	1	-	-
O-Ring	3	-	-
M8x25 Button head	1	-	-
M8x45 Button head	1	-	-
Washer M8 Ø 16	3	-	-
Lock nut M8	1	-	-
-	-	-	-

ALL IDEAS, DESIGNS ARRANGEMENTS AND PLANS INDICATED OR REPRESENTED BY THIS DRAWING ARE OWNED BY HYPERPRO AND WERE CREATED, EVOLVED AND DEVELOPED FOR USE ON AND IN CONNECTION WITH THE SPECIFIC PROJECT. NONE SUCH IDEAS, DESIGNS, ARRANGEMENTS OR PLANS SHALL BE USED BY OR DISCLOSED TO ANY PERSON, FIRM OR CORPORATION FOR ANY PURPOSE WHATSOEVER WITHOUT THE WRITTEN PERMISSION OF HYPERPRO.

**DAMPING ADJUSTER KNOB:**  
- turn CW to increase damping  
- turn CCW to decrease damping  
**NEVER USE MAXIMUM SETTING !!!**

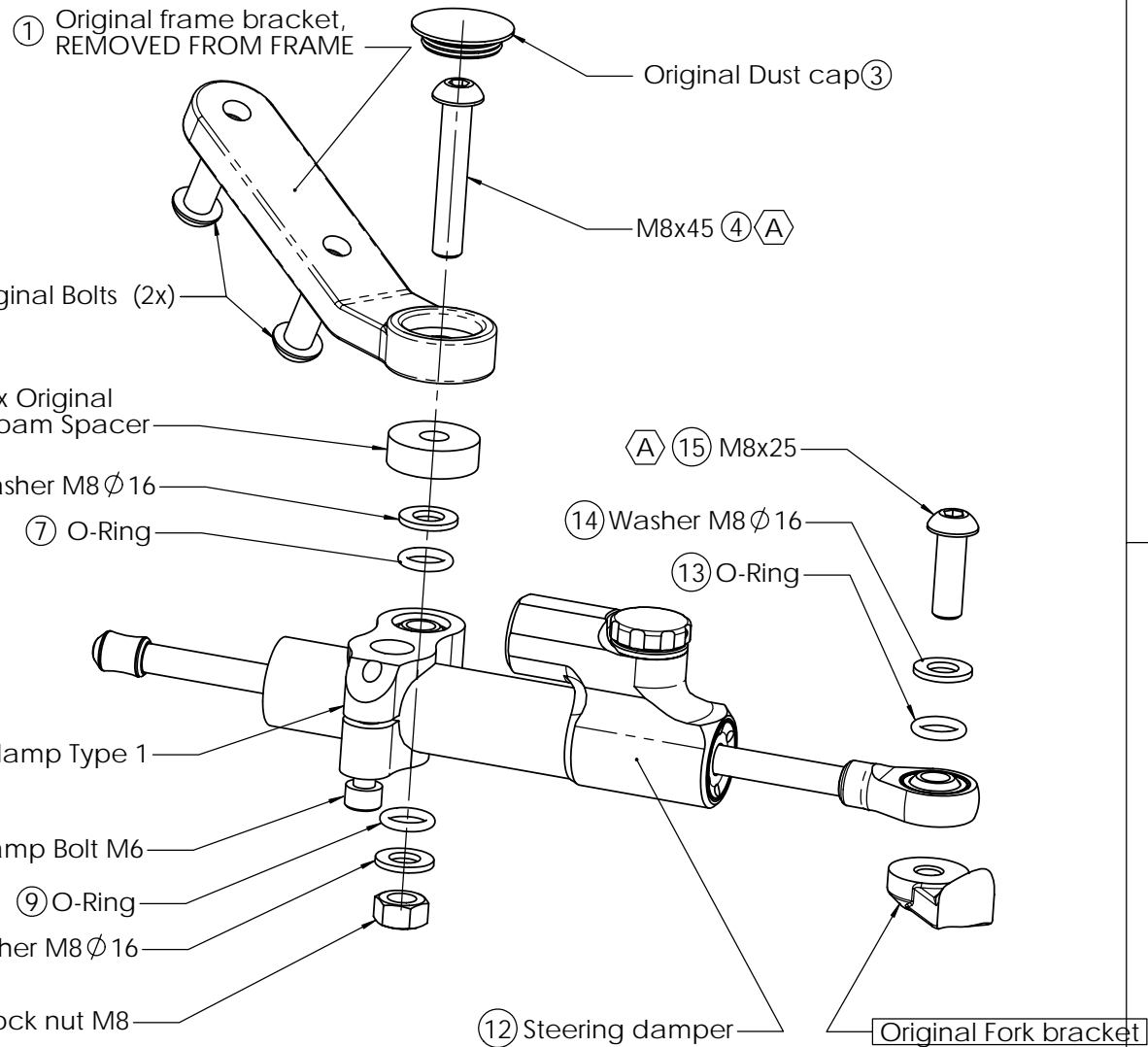
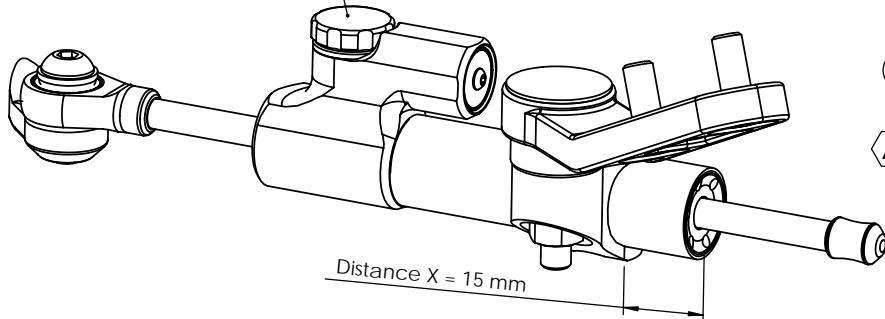

1  
of 2

- A 14-17Nm / 124-150Lbs.In / 10.3-12.5Lbs.Ft
- B 6Nm / 53Lbs.In / 4.4Lbs.Ft

# HYPERPRO

## STEERING DAMPER MOUNTING KIT

for

**BMW R1100R**  
**Model 1993 ->**

### MK-BM11-0001 INSTALLATION INSTRUCTIONS

#### **In general:**

HYPERPRO can not be held responsible in any way for any form of physical, material, financial or other damage arising from use, assembly or overhaul of HYPERPRO products. HYPERPRO reserves the right to make changes without prior notice.

This product is ONLY TO BE INSTALLED BY A PROFESSIONAL MECHANIC.

This product is only to be used for the motorcycle brand, model and year stated specifically on top of the pages of this manual.

DO NOT attempt to install this product on motorcycles from any different brand, model and/or year than stated on the pages of this manual.

DO NOT use this kit for cars, boats, jet-skies, snowmobiles, ATV's, aircraft, hovercrafts or any other vehicle and/or purpose.

HYPERPRO steering dampers are FOR RACE USE ONLY, NOT FOR HIGHWAY USE!

#### **Before installation:**

- Please read the entire manual carefully before starting the installation!
- Check if you have all the tools required. Good tools are a must.
- Protect your bike at the most important places in and around the work area (e.g. tank, fairing, frame, etc.), with a blanket, towel or similar.

#### **During installation:**

- Check all operations and parts carefully before, during and after performing each step.
- Clean all surfaces that are required for fitting parts together or for applying self adhesives or loctite, thoroughly with contact cleaner or another degreaser, unless otherwise stated.
- Be careful not to damage or scratch any part of your bike.
- ALWAYS work relaxed and concentrated!! It is very easy to damage something or make a mistake.

#### **After installation:**

- Check and make sure that there is no contact between any part of the steering damper kit and any part of the motorcycle. The kit should not hit anything. Steering movement should not be limited by the steering damper. If the steering movement is limited, adjust the position of the tube in the clamp until steering movement is normal again. Do not forget to tighten the clamp bolt again!
- ALWAYS check the steering movement and feeling before each ride!
- FIRST RIDES: Start with the damper turned fully open (turn adjuster knob fully counter clockwise). Start adjusting in between rides with steps of MAX. 2 CLICKS (0.25 TURN) EACH TIME, until the damper is working satisfactory for your riding style.
- NEVER USE MAXIMUM SETTING, ALWAYS OPEN AT LEAST 2 CLICKS (0.25 TURN).

- WARNING ! DAMPER HAS AN ACTIVE / SPEEDSENSITIVE DAMPING SYSTEM;
  - Steering with NORMAL MOVEMENT should be FREE !!
  - Steering with FAST MOVEMENT should be CONTROLLED BY DAMPER !!
- HYPERPRO uses a special seal to reduce friction. The seal uses an oil film to work properly. It is normal that some oil can appear on the pistonrod.
- Damper works with oil: DAMPING CAN BE HARDER AT LOWER TEMPERATURES!

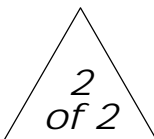

#### **Step 1: remove the original steering damper**

Remove the M8 bolt from the fork mounting point, releasing the ball joint of the original steering damper. Remove the complete original frame bracket (1) and steering damper from the bike by removing the 2 M8 bolts (2). Remove the dust cap (3) and loosen the bolt underneath it, separating the damper from the frame bracket (1). Do not throw away any original part, you will need some of them later.

#### **Step 2: installing the tube clamp**

- Original frame bracket (1)
- Original dust cap (3)
- Bolt M8x45 button head (4)
- 1x Original foam spacer (5)
- 2x Washer M8 Ø 16 (6, 10)
- 2x O-Ring (7, 9)
- TubeClamp TYPE 1 (8)
- Lock nut M8 (11)

Put the assembly together as shown on page 1: Take the frame bracket (1), put the bolt M8x45 (4) through from the top and place the spacer (5), washer (6), O-ring (7), tube-clamp (8), O-ring (9), washer (10) over the bolt in the correct order and position. Fit the M8 nut (11) and tighten the bolt and nut with a torque of approx. 14-17Nm/124-150Lbs.In/10.3-12.5Lbs.Ft. Reposition the dust cap (3) in its original position.

#### **Step 3: re-installing the frame bracket**

- Frame bracket assembly (from Step 2)
- 2x Original M8 bolt (2)

Re-install the frame bracket on its original place under the lower telelever arm. Use the 2 original M8 bolts (2) and tighten them with a torque of approx. 14-17Nm/124-150Lbs.In/10.3-12.5Lbs.Ft.

#### **Step 4: installing the steering damper**

- Steering damper (12)
- 1x O-ring (13)
- Washer M8 Ø 16 (14)
- Bolt M8x25 button head (15)

Ensure that the clamp bolt of the tube clamp (8) is pointing outward. Shove the damper (12), with the end knob-side first, through the clamp until the ball joint can be fitted to the original fork bracket. Use the O-ring (13), washer (14) and M8 bolt (15) to fixate the balljoint to the fork-bracket and tighten with a torque of approx. 14-17Nm/124-150Lbs.In/10.3-12.5Lbs.Ft. Position the damper tube until the distance "X" (=15mm) stated on page 1 is reached, then tighten the M6 clamp bolt (16) with a torque of approx. 6Nm/53Lbs.In/4.4Lbs.Ft.

Check if the damper does not touch anything (e.g. engine, fork) when steering from left to right. Check if the bike can make its full steering angle from left to right.

See [WWW.HYPERPRO.COM](http://WWW.HYPERPRO.COM) for the latest pictures, modifications, specs. and e-drawings of this steering damper kit.